

## Water Meter Pits

Model	Description	Weight
2-Piece	28" od/24" id 36" + 12" = 48"	860
3-Piece	28" od/24" id 24" + 12" + 12" = 48"	860
4-Piece	28" od/24" id 12"+12"+12"+12" = 48"	860
Tapered Ring	Reducer; 24" to 20"	150

\* Our truck can carry 18 meter pits per load

All meter pits are 2" thick, fully reinforced,  
 5,000 PSI mix design, wet-cast concrete

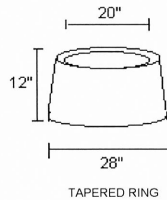

TAPERED RING

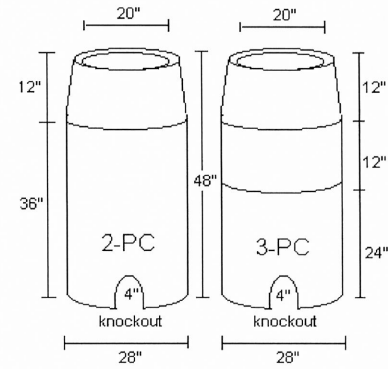

## 24" Riser Rings (28" OD/24" ID)

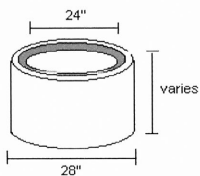

Model	Height	Weight
24x 3 riser ring	3"	45
24x 4 riser ring	4"	60
24x 6 riser ring	6"	90
24x 12 riser ring	12"	180
24x 24 riser ring	24"	360
24" Lid	2"	45
24" Lid	4"	145

All riser rings are 2" thick and have a lip so they can be nested one inside the other for varying heights  
 Pallet charge may apply

## 20" Riser Rings (24" OD/20" ID)

Model	Height	Weight
20x 2 riser ring	2"	30
20x 3 riser ring	3"	30
20x 4 riser ring	4"	40
20x 6 riser ring	6"	60
20x12 riser ring	12"	120
20" Lid	2"	30
36" Lid	2"	160

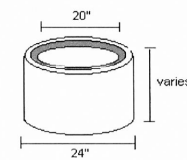

## Feed Bunks

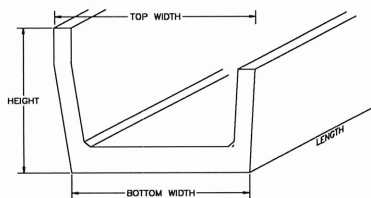

Model	Height	Bottom	Weight
8' Feed Bunk	27"	31"	2100
Two End Plates			
Legs			

## Retaining Walls

### Standard L-Wall Unit

Height	Length	Depth	Weight
3'	6'	24"	1200
4'	8'	27"	2380
6'	6'	36"	3100

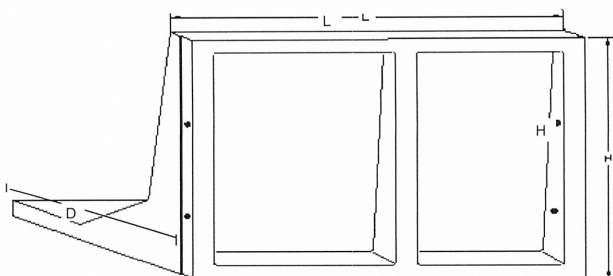

### T-Wall Unit

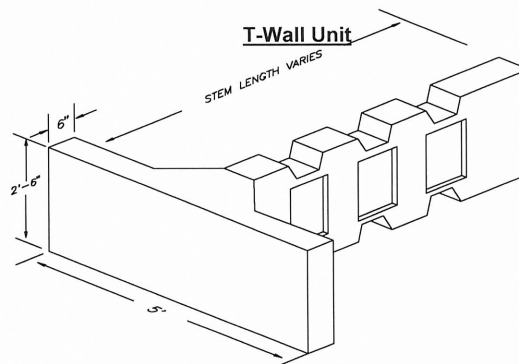

Stem Length	4'	6'	8'	10'	12'
Weight	1550	1800	2100	2350	2600

Stem Length	14'	16'	18'	20'
Weight	2900	3150	3400	3650

The face of each T-Wall unit is 5' wide and 2-6" tall and is available in various styles, including dry stack stone, rough hewn masonry blocks, and plain face, as shown. \* Please call the office for more information.

Delivery is available, standard charges apply.